

Galvanically isolated 4 A single gate driver for SiC MOSFETs



Features

- High voltage rail up to 1700 V
- Driver current capability: 4 A sink/source @25 °C
- dV/dt transient immunity ± 100 V/ns in full temperature range
- Overall input-output propagation delay: 75 ns
- Separate sink and source option for easy gate driving configuration
- 4 A Miller CLAMP dedicated pin option
- UVLO function
- Gate driving voltage up to 26 V
- 3.3 V, 5 V TTL/CMOS inputs with hysteresis
- Temperature shutdown protection
- Standby function
- 4.8 kV_{PK} isolation
- UL 1577 recognized
- Narrow body SO-8

Application

- Motor driver for home appliances, factory automation, industrial drives and fans.
- 600/1200 V inverters
- Battery chargers
- Induction heating
- Welding
- UPS
- Power supply units
- DC-DC converters
- Power Factor Correction

Description

The **STGAP2SICSN** is a single gate driver which provides galvanic isolation between the gate driving channel and the low voltage control and interface circuitry.

The gate driver is characterized by 4 A capability and rail-to-rail outputs, making the device also suitable for mid and high power applications such as power conversion and motor driver inverters in industrial applications. The device is available in two different configurations. The configuration with separated output pins allows to independently optimize turn-on and turn-off by using dedicated gate resistors. The configuration featuring single output pin and Miller CLAMP function prevents gate spikes during fast commutations in half-bridge topologies. Both configurations provide high flexibility and bill of material reduction for external components.

Product status link

[STGAP2SICSN](#)

Product label



The device integrates protection functions: UVLO with optimized value for SiC MOSFETs and thermal shutdown are included to easily design high reliability systems. Dual input pins allow choosing the control signal polarity and also implementing HW interlocking protection in order to avoid cross-conduction in case of controller malfunction. The input to output propagation delay results are contained within 75 ns, providing high PWM control accuracy. A standby mode is available in order to reduce idle power consumption.

1 Block diagram

Figure 1. Block diagram - Single output and Miller Clamp configuration

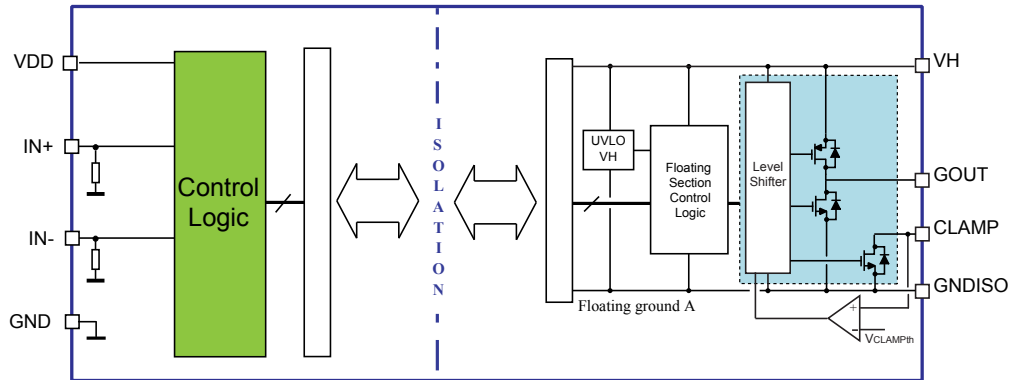
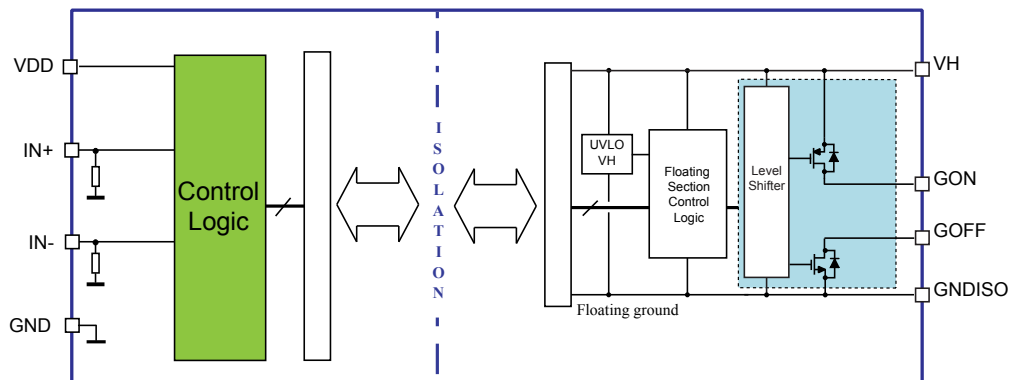

Figure 2. Block diagram - Separate outputs configuration



2 Pin description and connection diagram

Figure 3. Pin connection (top view), Separated outputs option

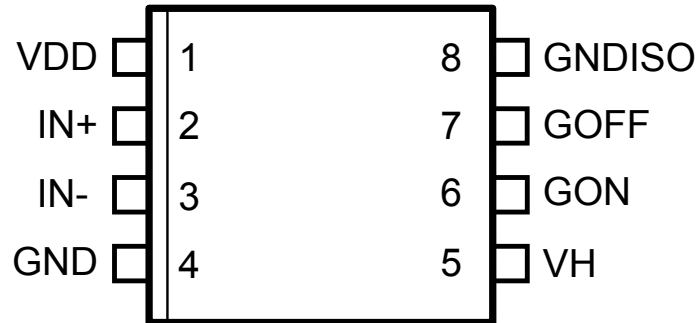

Figure 4. Pin connection (top view), Single output and Miller CLAMP option

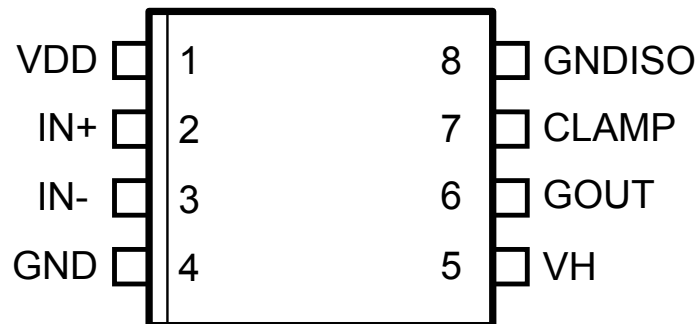

Table 1. Pin Description

Pin #		Pin name	Type	Function
Figure 3	Figure 4			
1	1	VDD	Power supply	Driver logic supply voltage.
2	2	IN+	Logic input	Driver logic input, active high.
3	3	IN-	Logic input	Driver logic input, active low.
4	4	GND	Power supply	Driver logic ground.
5	5	VH	Power supply	Gate driving positive voltage supply.
	6	GOUT	Analog output	Sink/Source output.
	7	CLAMP	Analog output	Active Miller Clamp.
6		GON	Analog output	Source output.
7		GOFF	Analog output	Sink output.
8	8	GNDISO	Power supply	Gate driving Isolated ground.

3 Electrical data

3.1 Absolute maximum ratings

Table 2. Absolute maximum ratings

Symbol	Parameter	Test condition	Min.	Max.	Unit
VDD	Logic supply voltage vs. GND		-0.3	6.5	V
V _{LOGIC}	Logic pins voltage vs. GND		-0.3	6.5	V
VH	Positive supply voltage (VH vs. GNDISO)		-0.3	28	V
V _{OUT}	Voltage on gate driver outputs (GON, GOFF, CLAMP vs. GNDISO)		-0.3	VH + 0.3	V
T _J	Junction temperature		-40	150	°C
T _S	Storage temperature		-50	150	°C
ESD	HBM (human body model)			2	kV

3.2 Thermal data

Table 3. Thermal data

Symbol	Parameter	Package	Value	Unit
R _{th(JA)}	Thermal resistance junction to ambient	SO-8	123	°C/W

3.3 Recommended operating conditions

Table 4. Recommended operating conditions

Symbol	Parameter	Test conditions	Min.	Max.	Unit
VDD	Logic supply voltage vs. GND		3.1	5.5	V
V _{LOGIC}	Logic pins voltage vs. GND		0	5.5	V
VH	Positive supply voltage (VH vs. GNDISO)		Max(V _{Hon})	26	V
V _{ISO-OP}	Input to output operative voltage (GND to GNDISO)	DC or peak	-1700	+1700	V
F _{SW}	Maximum switching frequency. ⁽¹⁾			1	MHz
t _{OUT}	Output Pulse width		100		ns
T _J	Operating Junction Temperature		-40	125	°C

1. Actual limit depends on power dissipation and T_J

4 Electrical characteristics

Table 5. Electrical characteristics ($T_J = 25^\circ\text{C}$, $V_H = 18\text{ V}$, $V_{DD} = 5\text{ V}$ unless otherwise specified)

Symbol	Pin	Parameter	Test conditions	Min.	Typ.	Max.	Unit
Dynamic characteristics							
t_{Don}	IN+, IN-	Input to output propagation delay ON		50	75	90	ns
t_{Doff}	IN+, IN-	Input to output propagation delay OFF		50	75	90	ns
t_r		Rise time	$C_L = 4.7\text{ nF}$ see Figure 12		30		ns
t_f		Fall time			30		ns
PWD		Pulse Width Distortion $t_{\text{Don}} - t_{\text{Doff}}$				20	ns
t_{deglitch}	IN+, IN-	Inputs deglitch filter			20	40	ns
CMTI ⁽¹⁾		Common-mode transient immunity, $ dv_{\text{ISO}}/dt $	$V_{\text{CM}} = 1500\text{ V}$, see Figure 13	100			V/ns
Supply voltage							
V_{Hon}	VH	VH UVLO turn-on threshold		14.6	15.5	16.4	V
V_{Hoff}	VH	VH UVLO turn-off threshold		13.9	14.8	15.7	V
V_{Hhyst}	VH	VH UVLO hysteresis		600	750	950	mV
I_{QHU}	VH	VH undervoltage quiescent supply current	$V_H = 7.0\text{ V}$		1.3	1.8	mA
I_{QH}	VH	VH quiescent supply current			1.3	1.8	mA
I_{QHSBY}	VH	Standby VH quiescent supply current	Standby mode		400	550	μA
SafeClp	GOUT / GOFF	GOFF active clamp	$I_{\text{GOFF}} = 0.2\text{ A}$; VH floating		2	2.3	V
I_{QDD}	VDD	VDD quiescent supply current			1.0	1.3	mA
I_{QDDSBY}	VDD	Standby VDD quiescent supply current	Standby mode		40	65	μA
Logic inputs							
V_{il}	IN+, IN-	Low-level logic threshold voltage		$0.29 \cdot V_{\text{DD}}$	$0.33 \cdot V_{\text{DD}}$	$0.37 \cdot V_{\text{DD}}$	V
V_{ih}	IN+, IN-	High-level logic threshold voltage		$0.62 \cdot V_{\text{DD}}$	$0.66 \cdot V_{\text{DD}}$	$0.70 \cdot V_{\text{DD}}$	V
I_{INh}	IN+, IN-	INx logic "1" input bias current	$I_{\text{Nx}} = 5\text{ V}$	33	50	70	μA
I_{INl}	IN+, IN-	INx logic "0" input bias current	$I_{\text{Nx}} = \text{GND}$			1	μA
R_{pd}	IN+, IN-	Inputs pull-down resistors	$I_{\text{Nx}} = 5\text{ V}$	70	100	150	k Ω
Driver buffer section							
I_{GON}	GOUT / GON	Source short-circuit current	$T_J = 25^\circ\text{C}$		4		A

Symbol	Pin	Parameter	Test conditions	Min.	Typ.	Max.	Unit
I_{GON}	GOUT / GON	Source short-circuit current	$T_J = -40 \div +125\text{ }^\circ\text{C}^{(1)}$	3		5	
V_{GONH}	GOUT / GON	Source output high-level voltage	$I_{GON} = 100\text{ mA}$	VH-0.15	VH-0.125		V
R_{GON}	GOUT / GON	Source R_{DS_ON}	$I_{GON} = 100\text{ mA}$		1.25	1.5	Ω
I_{GOFF}	GOUT / GOFF	Sink short-circuit current	$T_J = 25\text{ }^\circ\text{C}$		4		A
			$T_J = -40 \div +125\text{ }^\circ\text{C}^{(1)}$	3		5.5	
V_{GOFFL}	GOUT / GOFF	Sink output low-level voltage	$I_{GOFF} = 100\text{ mA}$		110	120	mV
R_{GOFF}	GOUT / GOFF	Sink R_{DS_ON}	$I_{GOFF} = 100\text{ mA}$		1.1	1.2	Ω
Miller clamp function							
$V_{CLAMPth}$	CLAMP	CLAMP voltage threshold	V_{CLAMP} vs. GNDISO	1.3	2	2.6	V
I_{CLAMP}	CLAMP	CLAMP short-circuit current	$V_{CLAMP} = 15\text{ V}$				A
			$T_J = 25\text{ }^\circ\text{C}$		4		
			$T_J = -40 \div +125\text{ }^\circ\text{C}^{(1)}$	2		5	
V_{CLAMP_L}	CLAMP	CLAMP low-level output voltage	$I_{CLAMP} = 100\text{ mA}$		96	115	mV
R_{CLAMP}	CLAMP	CLAMP R_{DS_ON}	$I_{CLAMP} = 100\text{ mA}$		0.96	1.15	Ω
Overtemperature protection							
T_{SD}		Shutdown temperature ⁽¹⁾		170			$^\circ\text{C}$
T_{hys}		Temperature hysteresis ⁽¹⁾			20		$^\circ\text{C}$
Standby							
t_{STBY}		Standby time	See Section 5.7	200	280	500	μs
t_{WUP}		Wake-up time	See Section 5.7	10	20	35	μs
t_{awake}		Wake-up delay	See Section 5.7	90	140	200	μs
$t_{stbyfilt}$		Standby filter	See Section 5.7	200	280	800	ns

1. Characterization data, not tested in production.

Table 6. Isolation related package specifications

Parameter	Symbol	Value	Unit	Conditions
Clearance (Minimum External Air Gap)	CLR	4	mm	Measured from input terminals to output terminals, shortest distance through air
Creepage (*) (Minimum External Tracking)	CPG	4	mm	Measured from input terminals to output terminals, shortest distance path along body
Comparative Tracking Index (Tracking Resistance)	CTI	≥ 400	V	DIN IEC 112/VDE 0303 Part 1
Isolation Group		II		Material Group (DIN VDE 0110, 1/89, Table 1)

Table 7. Isolation characteristics

Parameter	Symbol	Test conditions	Characteristic	Unit
Input to Output test voltage In accordance with VDE 0884-11	V_{PR}	Method a, Type test	2720	V_{PEAK}
		$V_{PR} = 2720, t_m = 10 \text{ s}$		
		Partial discharge < 5 pC		
		Method b1, 100 % Production test	3200	V_{PEAK}
		$V_{PR} = 3200, t_m = 1 \text{ s}$		
Partial discharge < 5 pC				
Transient Overvoltage (Highest Allowable Overvoltage)	V_{IOTM}	$t_{ini} = 60 \text{ s}$, Type test	4800	V_{PEAK}
Maximum Surge Test Voltage	V_{IOSM}	Type test	4800	V_{PEAK}
Isolation Resistance	R_{IO}	$V_{IO} = 500 \text{ V}$, Type test	$>10^9$	Ω

Table 8. UL 1577 Tests

Description	Symbol	Characteristic	Unit
Isolation Withstand Voltage, 1min (Type test)	V_{ISO}	2828/4000	V_{rms}/ P_{EAK}
Isolation Voltage, 1sec (100% production)	$V_{ISOtest}$	3394/4800	V_{rms}/ P_{EAK}

Recognized under the UL 1577 Component Recognition Program - file number E362869

5 Functional Description

5.1 Gate driving power supply and UVLO

The STGAP2SiCSN is a flexible and compact gate driver with 4 A output current and rail-to-rail outputs. The device allows implementation of either unipolar or bipolar gate driving.

Figure 5. Power supply configuration for unipolar and bipolar gate driving

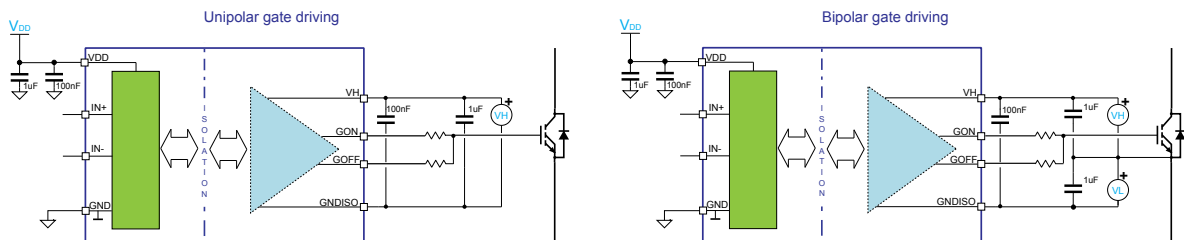

Undervoltage protection is available on VH supply pin. A fixed hysteresis sets the turn-off threshold, thus avoiding intermittent operation.

When VH voltage goes below the VH_{off} threshold, the output buffer goes into “safe state”. When VH voltage reaches the VH_{on} threshold, the device returns to normal operation and sets the output according to actual input pins status.

The VDD and VH supply pins must be properly filtered with local bypass capacitors. The use of capacitors with different values in parallel provides both local storage for impulsive current supply and high-frequency filtering. The best filtering is obtained by using low-ESR SMT ceramic capacitors, which are therefore recommended. A 100 nF ceramic capacitor must be placed as close as possible to each supply pin, and a second bypass capacitor with a value in the range between 1 μ F and 10 μ F should be placed close to it.

5.2 Power-up, power-down and ‘safe state’

The following conditions define the “safe state”:

- GOFF = ON state;
- GON = High Impedance;
- CLAMP = ON state (for STGAP2SiCSNC);

Such conditions are maintained at power-up of the isolated side ($VH < VH_{on}$) and during whole device power-down phase ($VH < VH_{off}$), regardless of the value of the input pins.

The device integrates a structure which clamps the driver output to a voltage not higher than SafeClp when VH voltage is not high enough to actively turn the internal GOFF MOSFET on. If VH positive supply pin is floating or not supplied, the GOFF pin is therefore clamped to a voltage smaller than SafeClp.

If the supply voltage VDD of the control section of the device is not supplied, the output is put into *safe state*, and remains in such condition until the VDD voltage returns within operative conditions.

After power-up of both isolated and low voltage side, the device output state depends on the input pins’ status.

5.3 Control inputs

The device is controlled through the IN+ and IN- logic inputs, in accordance with the truth table described in Table 9.

Table 9. Inputs truth table (applicable when device is not in UVLO or "safe state")

Input pins		Output pins	
IN+	IN-	GON	GOFF
L	L	OFF	ON
H	L	ON	OFF
L	H	OFF	ON
H	H	OFF	ON

A deglitch filter allows input signals with duration shorter than t_{deglitch} to be ignored, thereby preventing noise spikes potentially present in the application from generating unwanted commutations.

5.4 Miller Clamp function

The Miller Clamp function allows the control of the Miller current during the power stage switching in half-bridge configurations. When the external power transistor is in the OFF state, the driver operates to avoid the induced turn-on phenomenon that may occur when the other switch in the same leg is being turned on, due to the C_{GD} capacitance.

During the turn-off period the gate of the external switch is monitored through the CLAMP pin. The CLAMP switch is activated when gate voltage goes below the voltage threshold, V_{CLAMPth} , thus creating a low impedance path between the switch gate and the GNDISO pin.

5.5 Watchdog

The isolated HV side has a watchdog function in order to identify when it is not able to communicate with LV side, for example because the VDD of the LV side is not supplied. In this case the output of the driver is forced in "safe state" until communication link is properly established again.

5.6 Thermal shutdown protection

The device provides a thermal shutdown protection. When junction temperature reaches the T_{SD} temperature threshold, the device is forced into "safe state". The device operation is restored as soon as the junction temperature is lower than $T_{SD} - T_{hys}$.

5.7 Standby function

In order to reduce the power consumption of both control interface and gate driving sides the device can be put in standby mode. In standby mode the quiescent current from VDD and VH supply pins is reduced to I_{QDDBY} and I_{QHSDY} respectively, and the output remains in 'safe state' (the output is actively forced low).

The way to enter standby is to keep both IN+ and IN- high ("standby" value) for a time longer than t_{STBY} . During standby the inputs can change from the "standby" value.

To exit standby, IN+ and IN- must be put in any combination different from the "standby" value for a time longer than $t_{stbyfilt}$, and then in the "standby" value for a time t such that $t_{WUP} < t < t_{STBY}$.

When the input configuration is changed from the "standby" value the output is enabled and set according to inputs state after a time t_{awake} .

Figure 6. Standby state sequences

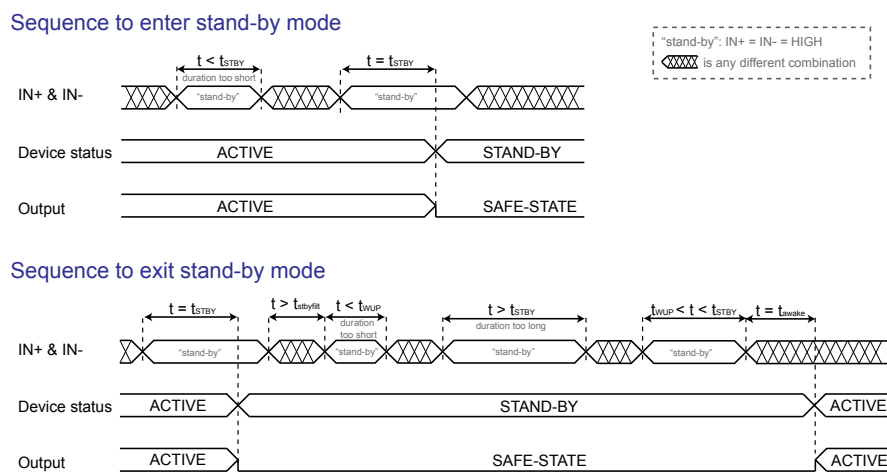

6 Typical application diagram

Figure 7. Typical application diagram - Separated outputs

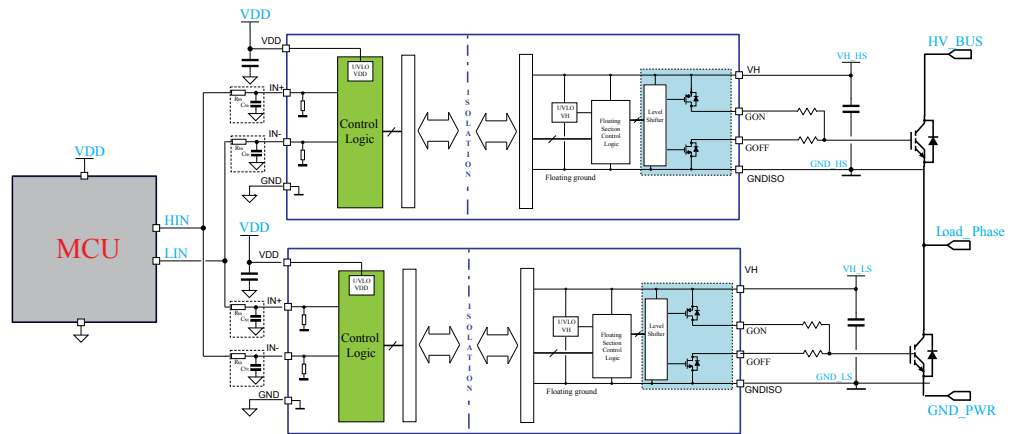

Figure 8. Typical application diagram - Separated outputs and negative gate driving

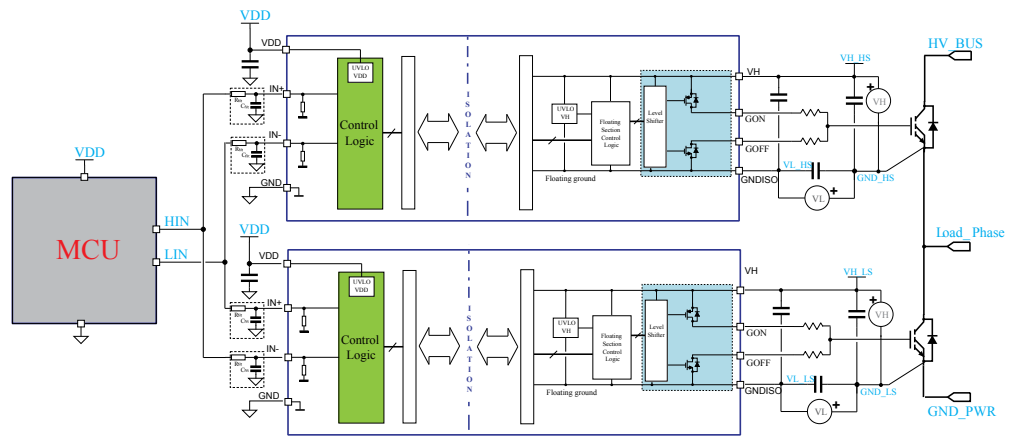

Figure 9. Typical application diagram - Miller Clamp

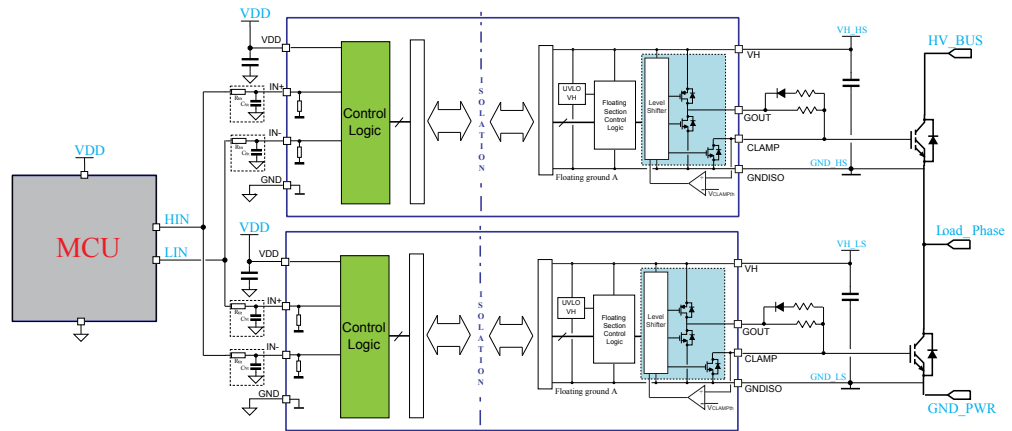
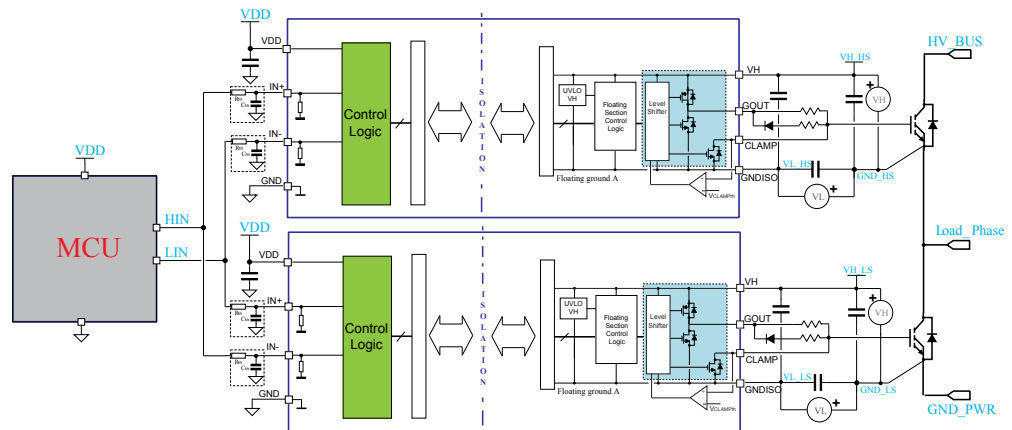

Figure 10. Typical application diagram - Miller Clamp and negative gate driving



7 Layout

7.1 Layout guidelines and considerations

In order to optimize the PCB layout, the following considerations should be taken into account:

- SMT ceramic capacitors (or different types of low-ESR and low-ESL capacitors) must be placed close to each supply rail pin. A 100 nF capacitor must be placed between VDD and GND and between VH and GNDISO, as close as possible to device pins, in order to filter high-frequency noise and spikes. In order to provide local storage for pulsed current a second capacitor with value in the range between 1 μ F and 10 μ F should also be placed close to the supply pins.
- As a good practice, it is suggested to add filtering capacitors close to logic inputs of the device (IN+, IN-), in particular for fast switching or noisy applications.
- The power transistors must be placed as close as possible to the gate driver, so to minimize the gate loop area and inductance that might lead to noise or ringing.
- To avoid degradation of the isolation between the primary and secondary side of the driver, there should not be any trace or conductive area below the driver.
- If the system has multiple layers, it is recommended to connect the VH and GNDISO pins to internal ground or power planes through multiple vias of adequate size. These vias should be located close to the IC pins to maximize thermal conductivity.

7.2 Layout example

An example of the STGAP2SiCSN half-bridge suggested PCB layout with main signals highlighted by different colors is shown in Figure 11. It is recommended to follow this example for proper positioning and connection of filtering capacitors.

Figure 11. Half-bridge suggested PCB layout

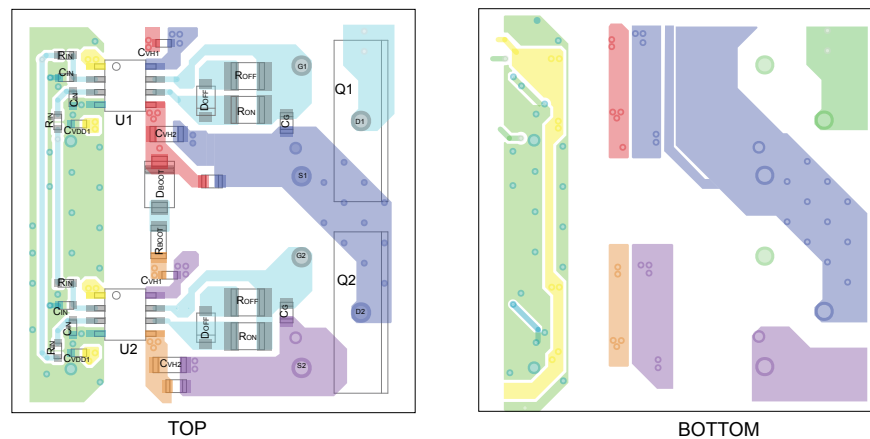

8 Testing and characterization information

Figure 12. Timings definition

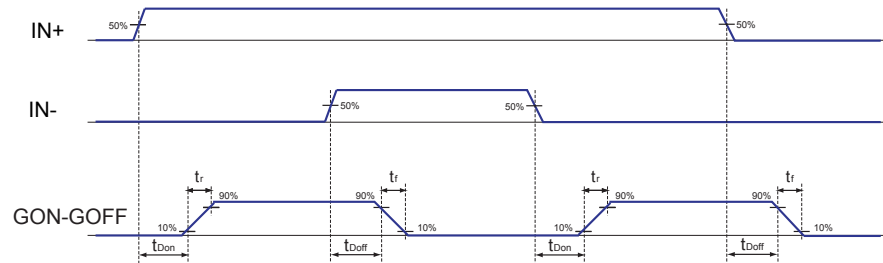
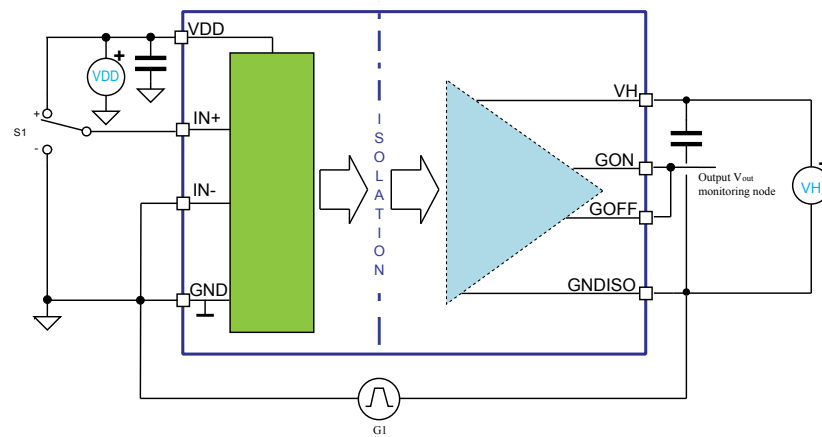

Figure 13. CMTI test circuit



9 Package information

In order to meet environmental requirements, ST offers these devices in different grades of **ECOPACK** packages, depending on their level of environmental compliance. ECOPACK specifications, grade definitions and product status are available at: www.st.com. ECOPACK is an ST trademark.

9.1 SO-8 package information

Dim.	mm			NOTES
	Min.	Typ.	Max.	
A	1.35	-	1.75	
A1	0.10	-	0.25	
b	0.35	-	0.49	
c	0.19	-	0.25	
D ⁽¹⁾	4.8	-	5	
E1	3.8	3.9	4	
E	5.8	6	6.2	
e	1.27 BSC			
L	0.4	-	1.25	
h	0.25	-	0.50	
θ	0°		7°	
Θ1	2°		12°	
aaa	0.25			
bbb	0.25			
ccc	0.1			

1. Dimension "D" does not include mold flash, protrusions, or gate burrs. Mold flash, protrusions or gate burrs shall not exceed 0.15 mm per side.

Figure 14. SO-8 mechanical data

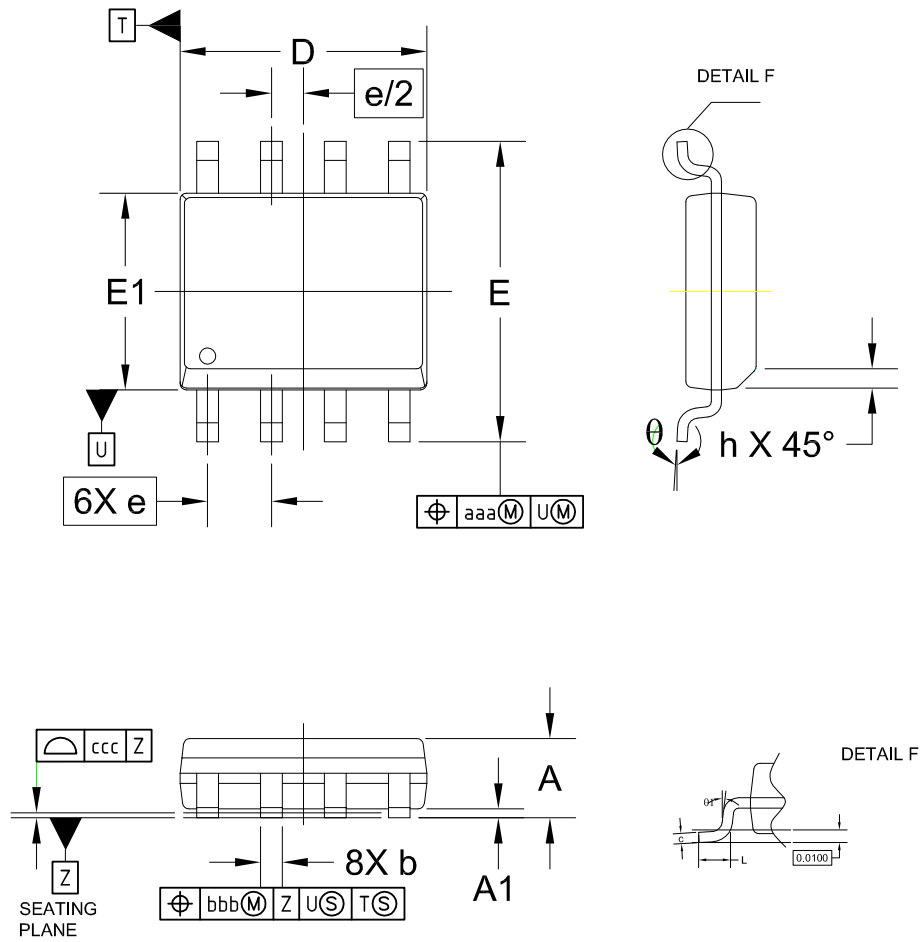

9.2 SO-8 Suggested land pattern

Figure 15. SO-8 suggested land pattern

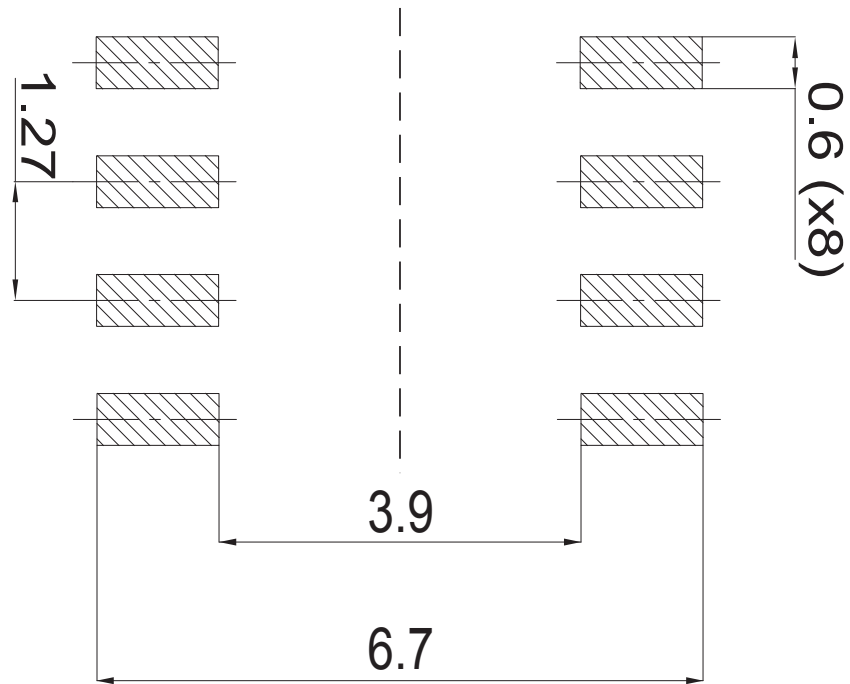

10 Ordering information

Table 10. Device summary

Order code	Output configuration	Package	Package marking	Packaging
STGAP2SiCSNTR	GON-GOFF	SO-8	GAP2ISN	Tape and Reel
STGAP2SiCSNCTR	GOUT-CLAMP	SO-8	GAP2ISCN	Tape and Reel

Revision history

Table 11. Document revision history

Date	Version	Changes
13-Aug-2021	1	Initial release.
19-Oct-2021	2	Updated test condition in Table 5 ; updated order codes.
29-Sep-2022	3	Added UL file certification

Contents

1	Block diagram	3
2	Pin description and connection diagram	4
3	Electrical data	5
3.1	Absolute maximum ratings	5
3.2	Thermal data	5
3.3	Recommended operating conditions	5
4	Electrical characteristics	6
5	Functional Description	9
5.1	Gate driving power supply and UVLO	9
5.2	Power-up, power-down and 'safe state'	9
5.3	Control inputs	10
5.4	Miller Clamp function	10
5.5	Watchdog	10
5.6	Thermal shutdown protection	10
5.7	Standby function	11
6	Typical application diagram	12
7	Layout	14
7.1	Layout guidelines and considerations	14
7.2	Layout example	14
8	Testing and characterization information	15
9	Package information	16
9.1	[Package name] package information	16
9.2	SO-8 Suggested land pattern	18
10	Ordering information	19
	Revision history	20
	Contents	21
	List of tables	22
	List of figures	23

List of tables

Table 1.	Pin Description	4
Table 2.	Absolute maximum ratings	5
Table 3.	Thermal data	5
Table 4.	Recommended operating conditions	5
Table 5.	Electrical characteristics ($T_J = 25^\circ\text{C}$, $V_H = 18\text{ V}$, $V_{DD} = 5\text{ V}$ unless otherwise specified)	6
Table 6.	Isolation related package specifications	7
Table 7.	Isolation characteristics	8
Table 8.	UL 1577 Tests	8
Table 9.	Inputs truth table (applicable when device is not in UVLO or "safe state")	10
Table 10.	Device summary	19
Table 11.	Document revision history	20

List of figures

Figure 1.	Block diagram - Single output and Miller Clamp configuration	3
Figure 2.	Block diagram - Separate outputs configuration	3
Figure 3.	Pin connection (top view), Separated outputs option	4
Figure 4.	Pin connection (top view), Single output and Miller CLAMP option	4
Figure 5.	Power supply configuration for unipolar and bipolar gate driving	9
Figure 6.	Standby state sequences	11
Figure 7.	Typical application diagram - Separated outputs	12
Figure 8.	Typical application diagram - Separated outputs and negative gate driving	12
Figure 9.	Typical application diagram - Miller Clamp	13
Figure 10.	Typical application diagram - Miller Clamp and negative gate driving	13
Figure 11.	Half-bridge suggested PCB layout	14
Figure 12.	Timings definition	15
Figure 13.	CMTI test circuit	15
Figure 14.	SO-8 mechanical data	17
Figure 15.	SO-8 suggested land pattern	18

IMPORTANT NOTICE – READ CAREFULLY

STMicroelectronics NV and its subsidiaries (“ST”) reserve the right to make changes, corrections, enhancements, modifications, and improvements to ST products and/or to this document at any time without notice. Purchasers should obtain the latest relevant information on ST products before placing orders. ST products are sold pursuant to ST’s terms and conditions of sale in place at the time of order acknowledgment.

Purchasers are solely responsible for the choice, selection, and use of ST products and ST assumes no liability for application assistance or the design of purchasers’ products.

No license, express or implied, to any intellectual property right is granted by ST herein.

Resale of ST products with provisions different from the information set forth herein shall void any warranty granted by ST for such product.

ST and the ST logo are trademarks of ST. For additional information about ST trademarks, refer to www.st.com/trademarks. All other product or service names are the property of their respective owners.

Information in this document supersedes and replaces information previously supplied in any prior versions of this document.

© 2022 STMicroelectronics – All rights reserved